

KMS100

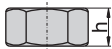

材 质	底座---不锈钢(SUS 304)
	螺杆、螺母---不锈钢(SUS 304)
	盘垫---橡胶
表面处理	底座---外观抛光镜面处理
功 能	防震、防滑、耐磨耗,螺杆可旋转活动。
备 注	螺母需另外购买

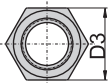
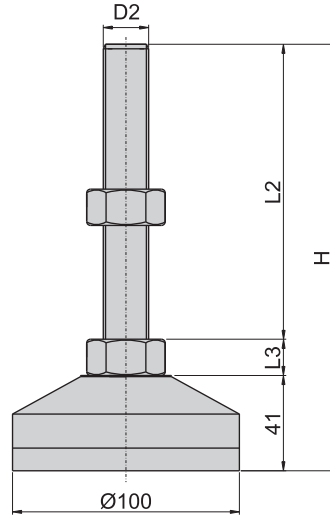

螺母编号	材 质	螺丝规格 mm/inch	对 边 D3/mm	螺母高度 h/mm
SM20	SUS304	M20 × P2.5	30	16
SM24		M24 × P3.0	36	19
SM30		M30 × P3.5	46	24

产品编号	螺母高度 L3/mm	螺丝规格 D2/mm/inch	螺丝长度 L2/mm	总 高 H/mm	荷 重 kg
KMS10020100	16	M20 × P2.5	100	157	2000
KMS10020130			130	187	
KMS10020150			150	207	
KMS10020200			200	257	
KMS10020250			250	307	
KMS10024100	19	M24 × P3.0	100	160	3000
KMS10024125			125	185	
KMS10024150			150	210	
KMS10024200			200	260	
KMS10024250			250	310	
KMS10030100	24	M30 × P3.5	100	165	5000
KMS10030150			150	215	
KMS10030200			200	265	
KMS10030250			250	310	
KMS10030300			300	365	